

# PILATES POWER GYM™ PLUS

## Resistance Charts

The Pilates Power Gym™ Plus offers you many options to increase or decrease resistance according to your fitness level and the specific exercise being performed. Resistance is varied by the number and combinations of Tension Cords used, the angle of the Glideboard, and body weight. The charts below and on the back of this sheet can be used to help you find the amount of resistance being applied when taking into consideration your body weight and the different Glideboard and Tension Cord settings.

Please reference pages 10 and 11 in your owner's manual for instructions and diagrams of how to adjust your Pilates Power Gym™ Plus unit.

In the charts below and on the back of this sheet, find the chart with the User Weight category closest to your own weight. In the first column on the left, labeled Cord Combinations, you will see symbols that represent which Tension Cords are attached to the unit. The symbol "⊙" represents no Cords attached to the Glideboard. The numbers you see in the black circles (①+②+③+④) represent the different Cords attached to the unit. The "+" symbol shows that multiple Cords are being used at the same time. The next column, Cord Resistance, shows approximately how many pounds of resistance are applied with each Cord or combination of Cords, without factoring in body weight or angle of Glideboard. Finally, the Position/Angle columns shown in blue represent the position and angle of the Glideboard. The numbers shown represent the approximate resistance a person close to the body weight indicated would have with each possible setting.

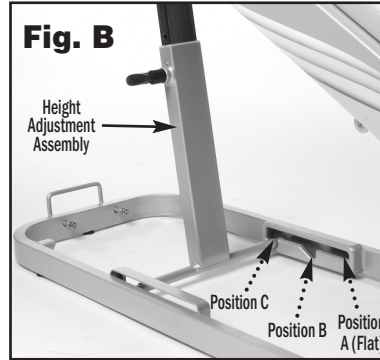

Fig. B  
Height Adjustment Assembly  
Position C  
Position B  
Position A (Flat)

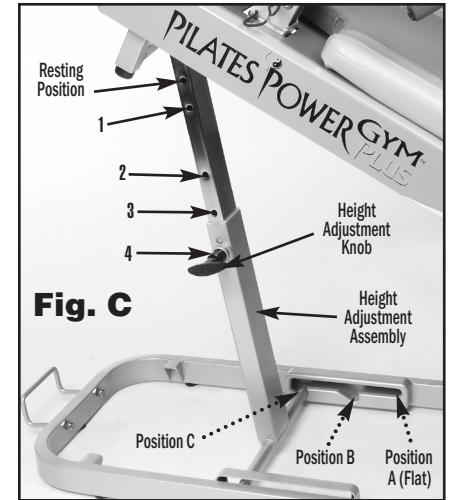

Fig. C  
Height Adjustment Knob  
Height Adjustment Assembly  
Position C  
Position B  
Position A (Flat)

^ Picture above and to the right are taken from the Owner's Manual. Please refer to pages 10 and 11 for more complete instruction to adjust the Pilates Power Gym™ Plus unit. >

\* Shown in Position C. For less resistance, move Height Adjustment Assembly to Position B.

User Weight: 100 lbs		Position / Angle										
CORD COMBINATIONS	CORD RESISTANCE (lbs.)	A-Resting / 0°	B-Resting / 8.1°	B-1 / 12°	C-Resting / 13.4°	C-1 / 16.2°	B-2 / 20.1°	C-2 / 22.8°	B-3 / 24.5°	C-3 / 26.5°	B-4 / 28.9°	C-4 / 30.3°
⊙	0	0.0	20.0	29.5	32.9	39.6	48.8	55.0	58.9	63.4	68.6	71.6
①	7.3	7.3	27.3	36.8	40.2	46.9	56.1	62.3	66.2	70.7	75.9	78.9
②	10.6	10.6	30.6	40.1	43.5	50.2	59.4	65.6	69.5	74.0	79.2	82.2
③	15.3	15.3	35.3	44.8	48.2	54.9	64.1	70.3	74.2	78.7	83.9	86.9
④	20.4	20.4	40.4	49.9	53.3	60.0	69.2	75.4	79.3	83.8	89.0	92.0
①+②	17.9	17.9	37.9	47.4	50.8	57.5	66.7	72.9	76.8	81.3	86.5	89.5
①+③	22.6	22.6	42.6	52.1	55.5	62.2	71.4	77.6	81.5	86.0	91.2	94.2
②+③	25.9	25.9	45.9	55.4	58.8	65.5	74.7	80.9	84.8	89.3	94.5	97.5
①+④	27.7	27.7	47.7	57.2	60.6	67.3	76.5	82.7	86.6	91.1	96.3	99.3
②+④	31.0	31.0	51.0	60.5	63.9	70.6	79.8	86.0	89.9	94.4	99.6	102.6
③+④	35.7	35.7	55.7	65.2	68.6	75.3	84.5	90.7	94.6	99.1	104.3	107.3
①+②+③	33.2	33.2	53.2	62.7	66.1	72.8	82.0	88.2	92.1	96.6	101.8	104.8
①+②+④	38.3	38.3	58.3	67.8	71.2	77.9	87.1	93.3	97.2	101.7	106.9	109.9
①+③+④	43.0	43.0	63.0	72.5	75.9	82.6	91.8	98.0	101.9	106.4	111.6	114.6
②+③+④	46.3	46.3	66.3	75.8	79.2	85.9	95.1	101.3	105.2	109.7	114.9	117.9
①+②+③+④	53.6	53.6	73.6	83.1	86.5	93.2	102.4	108.6	112.5	117.0	122.2	125.2

User Weight: 125 lbs		Position / Angle										
CORD COMBINATIONS	CORD RESISTANCE (lbs.)	A-Resting / 0°	B-Resting / 8.1°	B-1 / 12°	C-Resting / 13.4°	C-1 / 16.2°	B-2 / 20.1°	C-2 / 22.8°	B-3 / 24.5°	C-3 / 26.5°	B-4 / 28.9°	C-4 / 30.3°
⊙	0	0.0	23.5	34.7	38.7	46.6	57.4	64.7	69.3	74.5	80.7	84.3
①	7.3	7.3	30.8	42.0	46.0	53.9	64.7	72.0	76.6	81.8	88.0	91.6
②	10.6	10.6	34.1	45.3	49.3	57.2	68.0	75.3	79.9	85.1	91.3	94.9
③	15.3	15.3	38.8	50.0	54.0	61.9	72.7	80.0	84.6	89.8	96.0	99.6
④	20.4	20.4	43.9	55.1	59.1	67.0	77.8	85.1	89.7	94.9	101.1	104.7
①+②	17.9	17.9	41.4	52.6	56.6	64.5	75.3	82.6	87.2	92.4	98.6	102.2
①+③	22.6	22.6	46.1	57.3	61.3	69.2	80.0	87.3	91.9	97.1	103.3	106.9
②+③	25.9	25.9	49.4	60.6	64.6	72.5	83.3	90.6	95.2	100.4	106.6	110.2
①+④	27.7	27.7	51.2	62.4	66.4	74.3	85.1	92.4	97.0	102.2	108.4	112.0
②+④	31.0	31.0	54.5	65.7	69.7	77.6	88.4	95.7	100.3	105.5	111.7	115.3
③+④	35.7	35.7	59.2	70.4	74.4	82.3	93.1	100.4	105.0	110.2	116.4	120.0
①+②+③	33.2	33.2	56.7	67.9	71.9	79.8	90.6	97.9	102.5	107.7	113.9	117.5
①+②+④	38.3	38.3	61.8	73.0	77.0	84.9	95.7	103.0	107.6	112.8	119.0	122.6
①+③+④	43.0	43.0	66.5	77.7	81.7	89.6	100.4	107.7	112.3	117.5	123.7	127.3
②+③+④	46.3	46.3	69.8	81.0	85.0	92.9	103.7	111.0	115.6	120.8	127.0	130.6
①+②+③+④	53.6	53.6	77.1	88.3	92.3	100.2	111.0	118.3	122.9	128.1	134.3	137.9

User Weight: 150 lbs		Position / Angle										
CORD COMBINATIONS	CORD RESISTANCE (lbs.)	A-Resting / 0°	B-Resting / 8.1°	B-1 / 12°	C-Resting / 13.4°	C-1 / 16.2°	B-2 / 20.1°	C-2 / 22.8°	B-3 / 24.5°	C-3 / 26.5°	B-4 / 28.9°	C-4 / 30.3°
⊙	0	0.0	27.1	39.9	44.5	53.6	66.0	74.4	79.6	85.7	92.8	96.9
①	7.3	7.3	34.4	47.2	51.8	60.9	73.3	81.7	86.9	93.0	100.1	104.2
②	10.6	10.6	37.7	50.5	55.1	64.2	76.6	85.0	90.2	96.3	103.4	107.5
③	15.3	15.3	42.4	55.2	59.8	68.9	81.3	89.7	94.9	101.0	108.1	112.2
④	20.4	20.4	47.5	60.3	64.9	74.0	86.4	94.8	100.0	106.1	113.2	117.3
①+②	17.9	17.9	45.0	57.8	62.4	71.5	83.9	92.3	97.5	103.6	110.7	114.8
①+③	22.6	22.6	49.7	62.5	67.1	76.2	88.6	97.0	102.2	108.3	115.4	119.5
②+③	25.9	25.9	53.0	65.8	70.4	79.5	91.9	100.3	105.5	111.6	118.7	122.8
①+④	27.7	27.7	54.8	67.6	72.2	81.3	93.7	102.1	107.3	113.4	120.5	124.6
②+④	31.0	31.0	58.1	70.9	75.5	84.6	97.0	105.4	110.6	116.7	123.8	127.9
③+④	35.7	35.7	62.8	75.6	80.2	89.3	101.7	110.1	115.3	121.4	128.5	132.6
①+②+③	33.2	33.2	60.3	73.1	77.7	86.8	99.2	107.6	112.8	118.9	126.0	130.1
①+②+④	38.3	38.3	65.4	78.2	82.8	91.9	104.3	112.7	117.9	124.0	131.1	135.2
①+③+④	43.0	43.0	70.1	82.9	87.5	96.6	109.0	117.4	122.6	128.7	135.8	139.9
②+③+④	46.3	46.3	73.4	86.2	90.8	99.9	112.3	120.7	125.9	132.0	139.1	143.2
①+②+③+④	53.6	53.6	80.7	93.5	98.1	107.2	119.6	128.0	133.2	139.3	146.4	150.5

User Weight: 175 lbs		Position / Angle										
CORD COMBINATIONS	CORD RESISTANCE (lbs.)	A-Resting / 0°	B-Resting / 8.1°	B-1 / 12°	C-Resting / 13.4°	C-1 / 16.2°	B-2 / 20.1°	C-2 / 22.8°	B-3 / 24.5°	C-3 / 26.5°	B-4 / 28.9°	C-4 / 30.3°
⊙	0	0.0	30.6	45.1	50.3	60.5	74.6	84.1	90.0	96.8	104.9	109.5
①	7.3	7.3	37.9	52.4	57.6	67.8	81.9	91.4	97.3	104.1	112.2	116.8
②	10.6	10.6	41.2	55.7	60.9	71.1	85.2	94.7	100.6	107.4	115.5	120.1
③	15.3	15.3	45.9	60.4	65.6	75.8	89.9	99.4	105.3	112.1	120.2	124.8
④	20.4	20.4	51.0	65.5	70.7	80.9	95.0	104.5	110.4	117.2	125.3	129.9
①+②	17.9	17.9	48.5	63.0	68.2	78.4	92.5	102.0	107.9	114.7	122.8	127.4
①+③	22.6	22.6	53.2	67.7	72.9	83.1	97.2	106.7	112.6	119.4	127.5	132.1
②+③	25.9	25.9	56.5	71.0	76.2	86.4	100.5	110.0	115.9	122.7	130.8	135.4
①+④	27.7	27.7	58.3	72.8	78.0	88.2	102.3	111.8	117.7	124.5	132.6	137.2
②+④	31.0	31.0	61.6	76.1	81.3	91.5	105.6	115.1	121.0	127.8	135.9	140.5
③+④	35.7	35.7	66.3	80.8	86.0	96.2	110.3	119.8	125.7	132.5	140.6	145.2
①+②+③	33.2	33.2	63.8	78.3	83.5	93.7	107.8	117.3	123.2	130.0	138.1	142.7
①+②+④	38.3	38.3	68.9	83.4	88.6	98.8	112.9	122.4	128.3	135.1	143.2	147.8
①+③+④	43.0	43.0	73.6	88.1	93.3	103.5	117.6	127.1	133.0	139.8	147.9	152.5
②+③+④	46.3	46.3	76.9	91.4	96.6	106.8	120.9	130.4	136.3	143.1	151.2	155.8
①+②+③+④	53.6	53.6	84.2	98.7	103.9	114.1	128.2	137.7	143.6	150.4	158.5	163.1

# PILATES POWER GYM™ PLUS

## Resistance Charts

Please refer to the opposite side of this sheet for instructions on how to read the charts below.

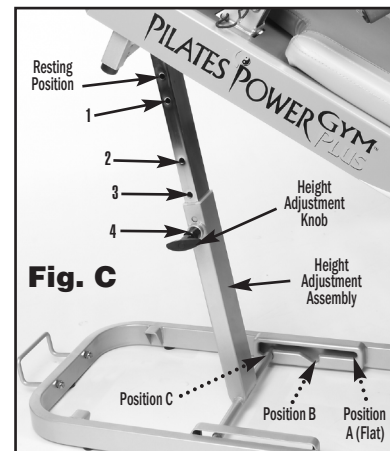
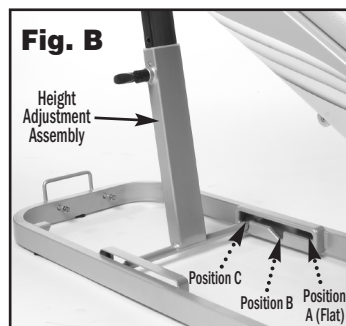

^ Picture above and to the right are taken from the Owner's Manual. Please refer to pages 10 and 11 for more complete instruction to adjust the Pilates Power Gym™ Plus unit. >

\* Shown in Position C. For less resistance, move Height Adjustment Assembly to Position B.

User Weight: 200 lbs

		Position / Angle										
CORD COMBINATIONS	CORD RESISTANCE (lbs.)	A-Resting / 0°	B-Resting / 8.1°	B-1 / 12°	C-Resting / 13.4°	C-1 / 16.2°	B-2 / 20.1°	C-2 / 22.8°	B-3 / 24.5°	C-3 / 26.5°	B-4 / 28.9°	C-4 / 30.3°
⊘	0	0.0	34.1	50.3	56.1	67.5	83.2	93.8	100.4	108.0	117.0	122.1
①	7.3	7.3	41.4	57.6	63.4	74.8	90.5	101.1	107.7	115.3	124.3	129.4
②	10.6	10.6	44.7	60.9	66.7	78.1	93.8	104.4	111.0	118.6	127.6	132.7
③	15.3	15.3	49.4	65.6	71.4	82.8	98.5	109.1	115.7	123.3	132.2	137.4
④	20.4	20.4	54.5	70.7	76.5	87.9	103.6	114.2	120.8	128.4	137.4	142.5
①+②	17.9	17.9	52.0	68.2	74.0	85.4	101.1	111.7	118.3	125.9	134.9	140.0
①+③	22.6	22.6	56.7	72.9	78.7	90.1	105.8	116.4	123.0	130.6	139.6	144.7
②+③	25.9	25.9	60.0	76.2	82.0	93.4	109.1	119.7	126.3	133.9	142.9	148.0
①+④	27.7	27.7	61.8	78.0	83.8	95.2	110.9	121.5	128.1	135.7	144.7	149.8
②+④	31.0	31.0	65.1	81.3	87.1	98.5	114.2	124.8	131.4	139.0	148.0	153.1
③+④	35.7	35.7	69.8	86.0	91.8	103.2	118.9	129.5	136.1	143.7	152.7	157.8
①+②+③	33.2	33.2	67.3	83.5	89.3	100.7	116.4	127.0	133.6	141.2	150.2	155.3
①+②+④	38.3	38.3	72.4	88.6	94.4	105.8	121.5	132.1	138.7	146.3	155.3	160.4
①+③+④	43.0	43.0	77.1	93.3	99.1	110.5	126.2	136.8	143.4	151.0	160.0	165.1
②+③+④	46.3	46.3	80.4	96.6	102.4	113.8	129.5	140.1	146.7	154.3	163.3	168.4
①+②+③+④	53.6	53.6	87.7	103.9	109.7	121.1	136.8	147.4	154.0	161.6	170.6	175.7

User Weight: 225 lbs

		Position / Angle										
CORD COMBINATIONS	CORD RESISTANCE (lbs.)	A-Resting / 0°	B-Resting / 8.1°	B-1 / 12°	C-Resting / 13.4°	C-1 / 16.2°	B-2 / 20.1°	C-2 / 22.8°	B-3 / 24.5°	C-3 / 26.5°	B-4 / 28.9°	C-4 / 30.3°
⊘	0	0.0	37.6	55.5	61.9	74.5	91.8	103.5	110.7	119.1	129.0	134.7
①	7.3	7.3	44.9	62.8	69.2	81.8	99.1	110.8	118.0	126.4	136.3	142.0
②	10.6	10.6	48.2	66.1	72.5	85.1	102.4	114.1	121.3	129.7	139.6	145.3
③	15.3	15.3	52.9	70.8	77.2	89.8	107.1	118.8	126.0	134.4	144.3	150.0
④	20.4	20.4	58.0	75.9	82.3	94.9	112.2	123.9	131.1	139.5	149.4	155.1
①+②	17.9	17.9	55.5	73.4	79.8	92.4	109.7	121.4	128.6	137.0	146.9	152.6
①+③	22.6	22.6	60.2	78.1	84.5	97.1	114.4	126.1	133.3	141.7	151.6	157.3
②+③	25.9	25.9	63.5	81.4	87.8	100.4	117.7	129.4	136.6	145.0	154.9	160.6
①+④	27.7	27.7	65.3	83.2	89.6	102.2	119.5	131.2	138.4	146.8	156.7	162.4
②+④	31.0	31.0	68.6	86.5	92.9	105.5	122.8	134.5	141.7	150.1	160.0	165.7
③+④	35.7	35.7	73.3	91.2	97.6	110.2	127.5	139.2	146.4	154.8	164.7	170.4
①+②+③	33.2	33.2	70.8	88.7	95.1	107.7	125.0	136.7	143.9	152.3	162.2	167.9
①+②+④	38.3	38.3	75.9	93.8	100.2	112.8	130.1	141.8	149.0	157.4	167.3	173.0
①+③+④	43.0	43.0	80.6	98.5	104.9	117.5	134.8	146.5	153.7	162.1	172.0	177.7
②+③+④	46.3	46.3	83.9	101.8	108.2	120.8	138.1	149.8	157.0	165.4	175.3	181.0
①+②+③+④	53.6	53.6	91.2	109.1	115.5	128.1	145.4	157.1	164.3	172.7	182.6	188.3

User Weight: 250 lbs

		Position / Angle										
CORD COMBINATIONS	CORD RESISTANCE (lbs.)	A-Resting / 0°	B-Resting / 8.1°	B-1 / 12°	C-Resting / 13.4°	C-1 / 16.2°	B-2 / 20.1°	C-2 / 22.8°	B-3 / 24.5°	C-3 / 26.5°	B-4 / 28.9°	C-4 / 30.3°
⊘	0	0.0	41.1	60.7	67.7	81.5	100.3	113.2	121.1	130.3	141.1	147.3
①	7.3	7.3	48.4	68.0	75.0	88.8	107.6	120.5	128.4	137.6	148.4	154.6
②	10.6	10.6	51.7	71.3	78.3	92.1	110.9	123.8	131.7	140.9	151.7	157.9
③	15.3	15.3	56.4	76.0	83.0	96.8	115.6	128.5	136.4	145.6	156.4	162.6
④	20.4	20.4	61.5	81.1	88.1	101.9	120.7	133.6	141.5	150.7	161.5	167.7
①+②	17.9	17.9	59.0	78.6	85.6	99.4	118.2	131.1	139.0	148.2	159.0	165.2
①+③	22.6	22.6	63.7	83.3	90.3	104.1	122.9	135.8	143.7	152.9	163.7	169.9
②+③	25.9	25.9	67.0	86.6	93.6	107.4	126.2	139.1	147.0	156.2	167.0	173.2
①+④	27.7	27.7	68.8	88.4	95.4	109.2	128.0	140.9	148.8	158.0	168.8	175.0
②+④	31.0	31.0	72.1	91.7	98.7	112.5	131.3	144.2	152.1	161.3	172.1	178.3
③+④	35.7	35.7	76.8	96.4	103.4	117.2	136.0	148.9	156.8	166.0	176.8	183.0
①+②+③	33.2	33.2	74.3	93.9	100.9	114.7	133.5	146.4	154.3	163.5	174.3	180.5
①+②+④	38.3	38.3	79.4	99.0	106.0	119.8	138.6	151.5	159.4	168.6	179.4	185.6
①+③+④	43.0	43.0	84.1	103.7	110.7	124.5	143.3	156.2	164.1	173.3	184.1	190.3
②+③+④	46.3	46.3	87.4	107.0	114.0	127.8	146.6	159.5	167.4	176.6	187.4	193.6
①+②+③+④	53.6	53.6	94.7	114.3	121.3	135.1	153.9	166.8	174.7	183.9	194.7	200.9

User Weight: 275 lbs

		Position / Angle										
CORD COMBINATIONS	CORD RESISTANCE (lbs.)	A-Resting / 0°	B-Resting / 8.1°	B-1 / 12°	C-Resting / 13.4°	C-1 / 16.2°	B-2 / 20.1°	C-2 / 22.8°	B-3 / 24.5°	C-3 / 26.5°	B-4 / 28.9°	C-4 / 30.3°
⊘	0	0.0	44.7	65.9	73.5	88.4	108.9	122.8	131.5	141.4	153.2	159.9
①	7.3	7.3	52.0	73.2	80.8	95.7	116.2	130.1	138.8	148.7	160.5	167.2
②	10.6	10.6	55.3	76.5	84.1	99.0	119.5	133.4	142.1	152.0	163.8	170.5
③	15.3	15.3	60.0	81.2	88.8	103.7	124.2	138.1	146.8	156.7	168.5	175.2
④	20.4	20.4	65.1	86.3	93.9	108.8	129.3	143.2	151.9	161.8	173.6	180.3
①+②	17.9	17.9	62.6	83.8	91.4	106.3	126.8	140.7	149.4	159.3	171.1	177.8
①+③	22.6	22.6	67.3	88.5	96.1	111.0	131.5	145.4	154.1	164.0	175.8	182.5
②+③	25.9	25.9	70.6	91.8	99.4	114.3	134.8	148.7	157.4	167.3	179.1	185.8
①+④	27.7	27.7	72.4	93.6	101.2	116.1	136.6	150.5	159.2	169.1	180.9	187.6
②+④	31.0	31.0	75.7	96.9	104.5	119.4	139.9	153.8	162.5	172.4	184.2	190.9
③+④	35.7	35.7	80.4	101.6	109.2	124.1	144.6	158.5	167.2	177.1	188.9	195.6
①+②+③	33.2	33.2	77.9	99.1	106.7	121.6	142.1	156.0	164.7	174.6	186.4	193.1
①+②+④	38.3	38.3	83.0	104.2	111.8	126.7	147.2	161.1	169.8	179.7	191.5	198.2
①+③+④	43.0	43.0	87.7	108.9	116.5	131.4	151.9	165.8	174.5	184.4	196.2	202.9
②+③+④	46.3	46.3	91.0	112.2	119.8	134.7	155.2	169.1	177.8	187.7	199.5	206.2
①+②+③+④	53.6	53.6	98.3	119.5	127.1	142.0	162.5	176.4	185.1	195.0	206.8	213.5

User Weight: 300 lbs

		Position / Angle										
CORD COMBINATIONS	CORD RESISTANCE (lbs.)	A-Resting / 0°	B-Resting / 8.1°	B-1 / 12°	C-Resting / 13.4°	C-1 / 16.2°	B-2 / 20.1°	C-2 / 22.8°	B-3 / 24.5°	C-3 / 26.5°	B-4 / 28.9°	C-4 / 30.3°
⊘	0	0.0	48.2	71.1	79.3	95.4	117.5	132.5	141.8	152.6	165.3	172.5
①	7.3	7.3	55.5	78.4	86.6	102.7	124.8	139.8	149.1	159.9	172.6	179.8
②	10.6	10.6	58.8	81.7	89.9	106.0	128.1	143.1	152.4	163.2	175.9	183.1
③	15.3	15.3	63.5	86.4	94.6	110.7	132.8	147.8	157.1	167.9	180.6	187.8
④	20.4	20.4	68.6	91.5	99.7	115.8	137.9	152.9	162.2	173.0	185.7	192.9
①+②	17.9	17.9	66.1	89.0	97.2	113.3	135.4	150.4	159.7	170.5	183.2	190.4
①+③	22.6	22.6	70.8	93.7	101.9	118.0	140.1	155.1	164.4	175.2	187.9	195.1
②+③	25.9	25.9	74.1	97.0	105.2	121.3	143.4	158.4	167.7	178.5	191.2	198.4
①+④	27.7	27.7	75.9	98.8	107.0	123.1	145.2	160.2	169.5	180.3	193.0	200.2
②+④	31.0	31.0	79.2	102.1	110.3	126.4	148.5	163.5	172.8	183.6	196.3	203.5
③+④	35.7	35.7	83.9	106.8	115.0	131.1	153.2	168.2	177.5	188.3	201.0	208.2
①+②+③	33.2	33.2	81.4	104.3	112.5	128.6	150.7	165.7	175.0	185.8	198.5	205.7
①+②+④	38.3	38.3	86.5	109.4	117.6	133.7	155.8	170.8	180.1	190.9	203.6	210.8
①+③+④	43.0	43.0	91.2	114.1	122.3	138.4	160.5	175.5	184.8	195.6	208.3	215.5
②+③+④	46.3	46.3	94.5	117.4	125.6	141.7	163.8	178.8	188.1	198.9	211.6	218.8
①+②+③+④	53.6	53.6	101.8	124.7	132.9	149.0	171.1	186.1	195.4	206.2	218.9	226.1